



DIAMOND SYSTEMS CORPORATION

RUBY-MM-1612

16-Channel 12-Bit Analog Output

PC/104 Module

User Manual V1.1

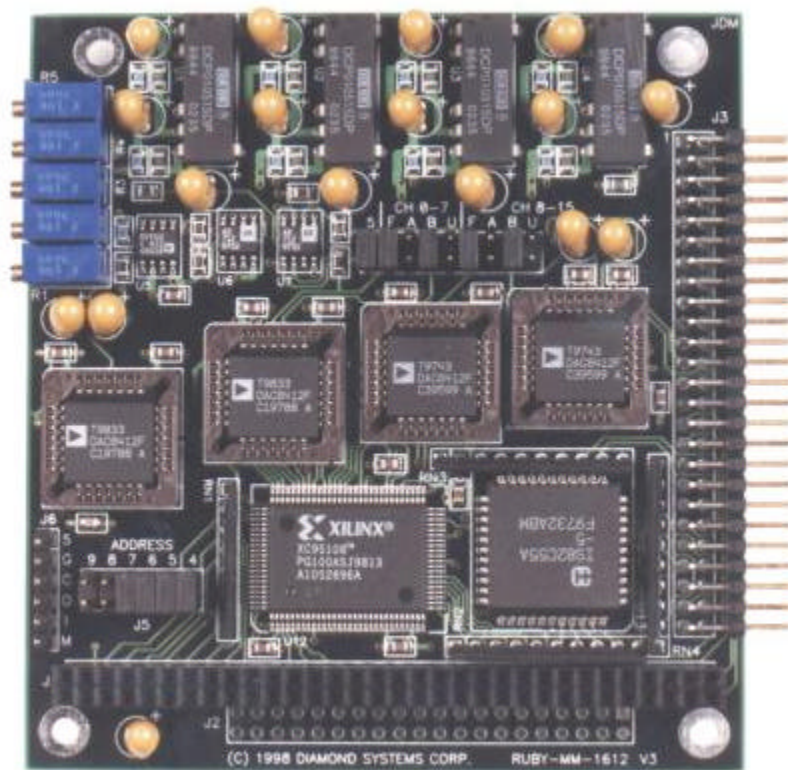

© Copyright 2001
Diamond Systems Corporation
8430-D Central Ave.
Newark, CA 94560
Tel (510) 456-7800
Fax (510) 45-7878
techinfo@diamondsystems.com
www.diamondsystems.com

TABLE OF CONTENTS

1.	DESCRIPTION.....	3
2.	I/O HEADER PINOUT.....	4
3.	BOARD CONFIGURATION	5
4.	ANALOG OUTPUT RANGE CONFIGURATION.....	6
5.	RUBY-MM-1612 BOARD DRAWING	8
6.	I/O MAP.....	9
7.	REGISTER DEFINITIONS	10
8.	82C55 DIGITAL I/O CHIP OPERATION	12
9.	ANALOG OUTPUT RANGES AND RESOLUTION	13
10.	D/A CODE COMPUTATION	14
11.	HOW TO GENERATE AN ANALOG OUTPUT	16
12.	CALIBRATION PROCEDURE.....	18
13.	SPECIFICATIONS.....	19

1. DESCRIPTION

Ruby-MM-1612 is a PC/104-format data acquisition board that provides analog outputs and digital I/O for process control and other applications. Below is a summary of key features:

Analog Outputs

Ruby-MM-1612 has 16 analog voltage outputs with 12-bit resolution (1 part in 4096).

⇒ **Note:** Analog output, D/A, and DAC are all used interchangeably in this manual.

Multiple Full-Scale Output Ranges

Six different preset ranges are available, including both bipolar and unipolar ranges.

Adjustable Full-Scale Output Range

One of the preset ranges (2.5V full-scale) can be adjusted by the user to any voltage between approximately 1V and 2.5V.

Simultaneous Update

All 16 analog outputs are updated simultaneously. This prevents time skew errors which can result from updating outputs sequentially on a system which requires two or more control signals to change simultaneously.

External Trigger

An external trigger signal can be connected to the board. This trigger can be used to update the analog outputs. The trigger is enabled in software.

Digital I/O

An 82C55 chip is included to provide 24 lines of digital I/O. Each line has a 10K Ω pull-up resistor. Each line is CMOS / TTL compatible and can supply up to ± 2.5 mA of current.

+5V Operation

Ruby-MM-1612 requires only +5VDC from the system power supply for operation. It generates its own ± 15 V supplies for the analog circuitry on board using four miniature DC/DC converters.

2. I/O HEADER PINOUT

Ruby-MM-1612 provides a 50-pin right-angle header labeled J3 for all user I/O. This header is located on the right side of the board. Pins 1, 2, 49, and 50 are marked to aid in proper orientation. A standard 50-pin cable-mount IDC (insulation displacement contact) connector will mate with this header.

J3 (Top of board)

Agnd	1	2	Vout 0
Agnd	3	4	Vout 1
Agnd	5	6	Vout 2
Agnd	7	8	Vout 3
Agnd	9	10	Vout 4
Agnd	11	12	Vout 5
Agnd	13	14	Vout 6
Agnd	15	16	Vout 7
Vout 8	17	18	Vout 9
Vout 10	19	20	Vout 11
Vout 12	21	22	Vout 13
Vout 14	23	24	Vout 15
DIO A7	25	26	DIO A6
DIO A5	27	28	DIO A4
DIO A3	29	30	DIO A2
DIO A1	31	32	DIO A0
DIO B7	33	34	DIO B6
DIO B5	35	36	DIO B4
DIO B3	37	38	DIO B2
DIO B1	39	40	DIO B0
DIO C7	41	42	DIO C6
DIO C5	43	44	DIO C4
DIO C3	45	46	DIO C2
DIO C1	47	48	DIO C0 / Ext Trig
+5V	49	50	Dgnd

Signal Name	Definition
Vout15 - 0	Analog output channels
Agnd	Analog ground
DIO A7-0, B7-0, C7-0	Digital I/O lines (programmable direction)
Ext Trig	Digital I/O line C0 can be used as an external D/A update signal
+5V	Connected to PC/104 bus +5V power supply
Dgnd	Digital ground

⇒ **Note:** The +5V and Dgnd lines do not need to be connected to a power supply to use this board. They are provided as connection points for convenience purposes only.

3. BOARD CONFIGURATION

Refer to the Drawing of Ruby-MM-1612 on Page 8 for locations of headers described in Chapters 3 and 4.

Base Address

Each board in the system must have a different base address. Use the pin header labeled J5, base address. The numbers above the jumpers correspond to the I/O address bits; bit 9 is the MSB and bit 0 is the LSB. Only bits 9 – 4 are used for the base address decoding. The remaining 4 bits 3-0 are assumed to be 0 for the base address. When a jumper is in, the corresponding base address bit is a 0, and when it is out, the bit is a 1.

The default address is 300 Hex = 1 1 0 0 0 0 0 0 0, so 9 8 are out and 7 6 5 4 are in. Any address above 100 Hex is a valid I/O address. However, there are many other circuits and boards sharing the I/O space, so you should check the documentation for your other boards to avoid conflicts. Below are some recommended I/O addresses for Ruby-MM-1612. Although the Base addresses can only be selected on 16-byte boundaries, Ruby-MM-1612 only uses the first 8 addresses.

Table 3.1: Base Address Configuration

Base Address		Header J5 Position					
Hex	Decimal	9	8	7	6	5	4
220	544	Out	In	In	In	Out	In
240	576	Out	In	In	Out	In	In
250	592	Out	In	In	Out	In	Out
260	608	Out	In	In	Out	Out	In
280	640	Out	In	Out	In	In	In
290	656	Out	In	Out	In	In	Out
2A0	672	Out	In	Out	In	Out	In
2B0	688	Out	In	Out	In	Out	Out
2C0	704	Out	In	Out	Out	In	In
2D0	720	Out	In	Out	Out	In	Out
2E0	736	Out	In	Out	Out	Out	In
300	768 (Default)	Out	Out	In	In	In	In
330	816	Out	Out	In	In	Out	Out
340	832	Out	Out	In	Out	In	In
350	848	Out	Out	In	Out	In	Out
360	864	Out	Out	In	Out	Out	In
380	896	Out	Out	Out	In	In	In
390	912	Out	Out	Out	In	In	Out
3A0	928	Out	Out	Out	In	Out	In
3C0	960	Out	Out	Out	Out	In	In
3E0	992	Out	Out	Out	Out	Out	In

4. ANALOG OUTPUT RANGE CONFIGURATION

Refer to the Drawing of Ruby-MM-1612 on Page 8 for locations of headers described in Sections 3 and 4. Refer to Figure 4.1 on Page for an explanation of the voltage reference circuitry. Also refer to Table 4.1 for a quick guide to output range configuration and jumper settings.

Header **J4** is used to configure the analog outputs. Four items are configurable: (1) On-board reference full-scale voltage, (2) D/A full-scale voltage, (3) unipolar / bipolar select, and (4) adjustable reference voltage. Items 2 and 3 in turn are configured separately for each bank of 8 analog output channels.

On-Board Reference Full-Scale Voltage Selection

An on-board reference voltage generator provides a +5.000V full-scale voltage output. This voltage is used as the basis for all on-board full-scale output ranges. This +5 reference drives an operational amplifier, from which the fixed references are derived. The gain of this amplifier is normally set to 1, so that its output is also +5.000V. However, you can change the gain to 2 so that the output is +10.00V. For an output of +5V, install a jumper in location **5** in header J4. For an output of +10V, remove the jumper from this location. The output of this amplifier is used to generate the full-scale voltages for both bipolar and unipolar output ranges.

D/A Full-Scale Voltage

The full-scale voltage defines the full output range capability of the analog outputs. Locations **F A** on header **J4** are used to select the full-scale voltage. Each bank of eight channels has its own selection pins for full-scale voltage. Thus each bank of eight channels may be configured differently. Install only one jumper in these locations for each bank of channels. Position **F** is for the Full-scale voltage (5V or 10V depending on the jumper in position 2, explained above). This is the default setting. Position **A** is for the Adjustable reference voltage (see section 4.4).

Unipolar / Bipolar Output Range

Unipolar output ranges are positive voltages only (for example 0 - 5V), while bipolar output ranges include both positive and negative voltages (for example $\pm 5V$). To select unipolar outputs, install a jumper in position **U** on J4. to select bipolar outputs, install a jumper in position **B**. Install only one jumper in these locations for each bank of channels.

Adjustable Reference Voltage

One full-scale voltage range is adjustable by the user. It is preset to 2.5V (for both 0-2.5V and $\pm 2.5V$ ranges), but may be set anywhere between 0V and 2.5V. To adjust this voltage, apply a voltmeter to the top pin of header **J4** underneath either **A** mark and turn the screw on potentiometer **R4** (the fourth from the left / second from the right in the row of blue potentiometers at the top of the board) until the voltmeter reads the desired voltage.

Table 4.1: Analog Output Configuration (Header J4)

Range	5	F	A	B	U
0-5V:	X	X			X
0-10V:		X			X
+/-5V:	X	X		X	
+/-10V:		X		X	
0-2.5V:	X		X		X
or			X		X
+/-2.5V:	X		X	X	
or			X	X	

An X means that a jumper is installed in that location. Only one half of pin header J4 is shown. Positions F A B U are repeated for each bank of 8 channels.

⇒ **Note:** Each bank of eight channels (0 - 7 and 8 - 15) can have a different output range setting. However, all eight channels within a bank will always have the same output range.

5. RUBY-MM-1612 BOARD DRAWING

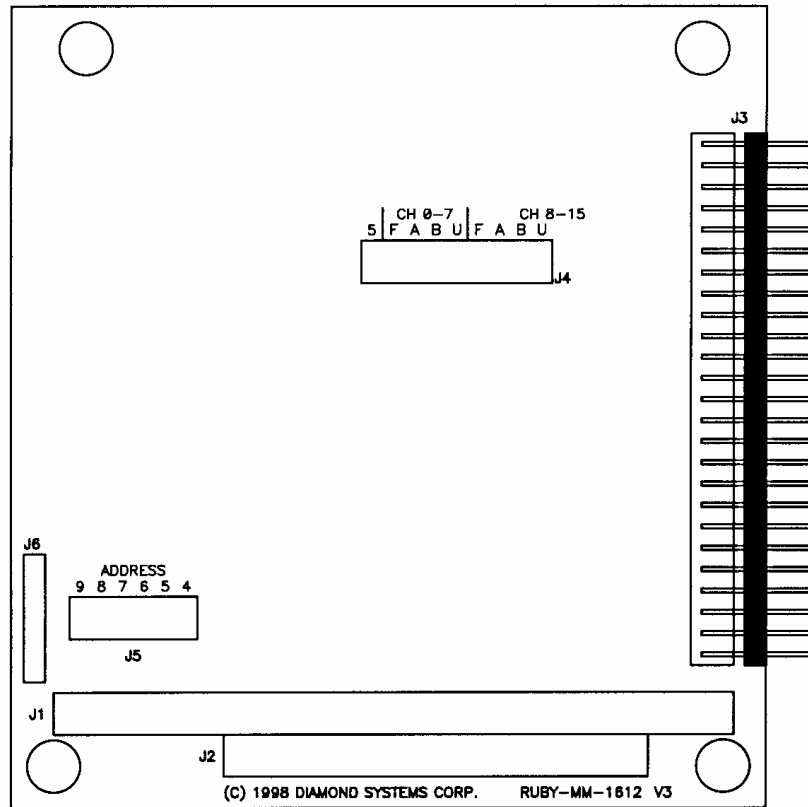

- J1: PC/104 8-bit bus header
- J2: PC/104 16-bit bus header (not used)
- J3: User I/O header
- J4: Analog output range configuration header
- J5: Base address selection header
- J6: ISP header for factory use only; do not connect

6. I/O MAP

Ruby-MM-1612 occupies 8 consecutive 8-bit locations in I/O space. For example, the default base address is 300 Hex (768 Decimal); in this case the board occupies addresses 300 - 307 (768 - 775). The first 2 locations are used individually for each analog output channel. Since analog output data is 12 bits wide, it is broken into two bytes. The first byte contains the 8 least significant bits (called the LSB) of the D/A data, and the 4 lowest bits of the second byte contain the 4 most significant bits (called the MSB) of the D/A data. The 4 highest bits of the second byte are not used. The DACs are updated all at once when Base or Base+1 is read. The value read from these locations is not predictable and not meaningful. Only the act of reading from the board is required to perform the update.

Ruby-MM-1612 I/O Map

<u>Base +</u>	<u>Write Function</u>	<u>Read Function</u>
0	DAC LSB (all DACs)	Update all DACs simultaneously
1	DAC MSB (all DACs)	Update all DACs simultaneously
2	DAC channel register	NA
3	External trigger enable	NA
4	Digital I/O port A data	Digital I/O port A data
5	Digital I/O port B data	Digital I/O port B data
6	Digital I/O port C data	Digital I/O port C data
7	Digital I/O control register	Digital I/O control register

Reset information:

A system hardware reset will also reset the board.

During a reset, the following occurs:

- All analog outputs are set to mid-scale (0V for bipolar ranges and 1/2 full-scale for unipolar ranges).
- The external trigger register is set to 0, disabling external trigger.
- All digital I/O lines are set to input mode.

The next chapter describes all registers on the board. You should familiarize yourself with these registers in order to get a complete understanding of the board's operation.

7. REGISTER DEFINITIONS

Base + 0, Write: DAC LSB register

Bit No.	7	6	5	4	3	2	1	0
Name	DA7	DA6	DA5	DA4	DA3	DA2	DA1	DA0

DA7-0 D/A data bits 7-0. DA0 is the LSB (least significant bit).

Base + 1, Write: DAC MSB register

Bit No.	7	6	5	4	3	2	1	0
Name	X	X	X	X	DA11	DA10	DA9	DA8

X Bit not used. These bits will be ignored.

DA11-8 D/A data bits 11-8. DA11 is the MSB (most significant bit).

Base + 0 or 1, Read: Update DACs

Reading from these locations updates all DACs to the values written to them. Only DACs with new data written to them will change. The remaining channels will retain their current values.

Base + 2, Write: DAC channel register

Bit No.	7	6	5	4	3	2	1	0
Name	X	X	X	X	CH3	CH2	CH1	CH0

X Bit not used. These bits will be ignored.

CH3-0 D/A Channel no. There are 16 channels numbered 0 to 15.

Base + 3, Write: External trigger register

Bit No.	7	6	5	4	3	2	1	0
Name	X	X	X	X	X	X	X	TRIGEN

X Bit not used. These bits will be ignored.

TRIGEN External trigger enable. 1 = enable, 0 = disable. When external trigger is enabled, digital I/O line C0 will update all DACs simultaneously when it is brought low. This can be done either by an external signal, when C0 is in input mode, or in software, when C0 is in output mode.

If using an external trigger, make sure that the lower half of Port C is in input mode.

Base + 4 through Base + 7 Read/Write 82C55 Digital I/O Registers

These registers map directly to the 82C55 digital I/O chip. The definitions of these registers can be found in the 82C55 datasheet appended to the back of this manual. A short form description is on the next page.

These lines power up in input mode. Each line has a 10K Ω pull-up resistor, so on power-up or system reset, all lines will indicate a logic high.

8. 82C55 DIGITAL I/O CHIP OPERATION

This is a short form description of the 82C55 digital I/O chip on the board. A full datasheet is included at the back of this manual.

82C55 Register Map

Base + n, Dir, Function	D7	D6	D5	D4	D3	D2	D1	D0
4, R/W, Port A	A7	A6	A5	A4	A3	A2	A1	A0
5, R/W, Port B	B7	B6	B5	B4	B3	B2	B1	B0
6, R/W, Port C	C7	C6	C5	C4	C3	C2	C1	C0
7, W, Config Register	1	ModeC	ModeA	DirA	DirCH	ModeB	DirB	DirCL

Configuration Register

The configuration register is programmed by writing to Base + 7 using the format below. Once you have set the port directions with this register, you can read and write to the ports as desired.

Bit No.	7	6	5	4	3	2	1	0
Name	1	ModeC	ModeA	DirA	DirCH	ModeB	DirB	DirCL

Definitions:

- 1 Bit 7 must be set to 1 to indicate port mode set operation.
- DirA Direction control for bits A7 – A0: 0 = output, 1 = input
- DirB Direction control for bits B7 – B0: 0 = output, 1 = input
- DirCL Direction control for bits C3 – C0: 0 = output, 1 = input
- DirCH Direction control for bits C7 – C4: 0 = output, 1 = input
- ModeA, ModeB, ModeC I/O Mode for each port, 0 or 1

Here is a list of common configuration register values (others are possible):

Configuration Byte		Port A	Port B	Port C (both halves)	
Hex	Decimal				
9B	155	Input	Input	Input	(all ports input)
92	146	Input	Input	Output	
99	153	Input	Output	Input	
90	144	Input	Output	Output	
8B	139	Output	Input	Input	
82	130	Output	Input	Output	
89	137	Output	Output	Input	
80	128	Output	Output	Output	(all ports output)

9. ANALOG OUTPUT RANGES AND RESOLUTION

The table below lists the available fixed full-scale output ranges and their corresponding actual full-scale voltage ranges and resolution.

For any output range, the resolution is equal to the maximum possible range of output voltages divided by the maximum number of possible steps. For a 12-bit D/A converter as is used on the Ruby-MM-1612, the maximum number of steps is $2^{12} = 4096$ (the actual output codes range from 0 to 4095, which is the full range of possible 12-bit binary numbers). Thus the resolution is equal to 1/4096 times the full-scale range. This is the smallest possible change in the output and corresponds to a change of 1 in the output code. Because of this fact the resolution is often referred to as the value of **1 LSB**, or 1 least significant bit.

Table 10.1: Analog Output Ranges and Resolution

Full-Scale Voltage	Unipolar or Bipolar	Range Name	Negative Full Scale	Positive Full Scale	Resolution (1LSB)
10V	Unipolar	0-10V	0V	+9.9976V	2.44mV
5V	Unipolar	0-5V	0V	+4.9988V	1.22mV
2.5V	Unipolar	0-2.5V	0V	+2.4994V	0.61mV
10V	Bipolar	±10V	-10V	+9.9951V	4.88mV
5V	Bipolar	±5V	-5V	+4.9963V	2.44mV
2.5V	Bipolar	±2.5V	-2.5V	+2.4988V	1.22mV

In the table above, *negative full scale* refers to the output voltage for a code of 0, and *positive full scale* refers to the output voltage for a code of 4095.

10. D/A CODE COMPUTATION

Two different methods are used to compute the 12-bit D/A code used for analog output operations.

For *unipolar* output ranges (positive voltages only), *straight binary coding* is used.

For *bipolar* output ranges (both positive and negative voltages), *offset binary coding* is used.

For any output range, the resolution is equal to the maximum possible range of output voltages divided by the maximum number of possible steps. For a 12-bit D/A converter as is used on the Ruby-MM-1612, the maximum number of steps is $2^{12} = 4096$ (the actual output codes range from 0 to 4095, which is the full range of possible 12-bit binary numbers). Thus the resolution is equal to $1/4096$ times the full-scale range. This is the smallest possible change in the output and corresponds to a change of 1 in the output code. Because of this fact the resolution is often referred to as the value of **1 LSB**, or 1 least significant bit.

Straight Binary Coding (for unipolar output ranges)

This is the simplest form of binary coding. The output voltage is given by:

$$\text{Output Voltage} = (\text{Output Code} / 4096) \times \text{Full-Scale Voltage}$$

Example: Output code = 1024, full-scale voltage = 5V
 Output voltage = $(1024 / 4096) \times 5 = .25 \times 5 = \mathbf{1.250V}$

Conversely, the output code for a desired output voltage is given by:

$$\text{Output Code} = (\text{Desired Output Voltage} / \text{Full-Scale Voltage}) \times 4096$$

Example: Desired output voltage = 0.485V, Full-scale voltage = 2.5V
 Output Code = $(0.485 / 2.5) \times 4096 = 0.194 \times 4096 = \mathbf{795}$ (rounded up)

The relationship between D/A resolution and Full-scale voltage is:

$$\mathbf{1 \text{ LSB} = 1/4096 \times \text{Full-Scale Voltage}}$$

Example: Full-scale voltage = 5V; 1 LSB = $5V / 4096 = 1.22\text{mV}$

Here is a brief overview of the relationship between output code and output voltage:

<u>Output Code</u>	<u>Explanation</u>	<u>Output Voltage for 0-5V Range</u>
0	0V	0V
1	1 LSB	.0024V (2.44mV)
2048	1/2 positive full scale	2.5V
4095	Positive full scale - 1 LSB	4.9988V

⇒ **Note:** In order to generate an output voltage of positive full scale, you would have to output a code of 4096 ($4096 / 4096 \times \text{full-scale} = \text{full-scale}$). However, 4096 is a 13-bit number which cannot be reproduced on a 12-bit D/A converter. The highest number that can be output is 4095, which is $4096 - 1$. This results in a maximum output voltage of full scale minus 1 LSB for any analog output range. This phenomenon is true for all D/A and A/D converters.

Offset Binary Coding (for bipolar output ranges)

This method takes into account the fact that the lowest output voltage is not zero but a negative value. The output voltage is given by:

$$\text{Output Voltage} = (\text{Output Code} / 2048) \times \text{Full-Scale Voltage} - \text{Full-Scale Voltage}$$

Example: Output code = 1024, full-scale voltage = 5V
 Output voltage = $(1024 / 2048) \times 5 - 5 = (0.5 \times 5) - 5 = -2.500\text{V}$

Note the difference between this output voltage to the output voltage using straight binary coding shown above using the same output code.

Conversely, the output code for a desired output voltage is given by:

$$\text{Output Code} = (\text{Desired Output Voltage} / \text{Full-Scale Voltage}) \times 2048 + 2048$$

Example: Desired output voltage = 0.485V, Full-scale voltage = 2.5V
 Output Code = $(0.485 / 2.5) \times 2048 + 2048 = 0.194 \times 2048 + 2048 = 2445$
 (rounded down)

The relationship between D/A resolution and Full-scale voltage is:

$$1 \text{ LSB} = 1/2048 \times \text{Full-Scale Voltage}$$

Example: Full-scale voltage = 5V; 1 LSB = $5\text{V} / 2048 = 2.44\text{mV}$

The reason that 1 LSB for a bipolar range is twice the magnitude of 1 LSB for a unipolar range with the same full-scale voltage is that for the bipolar range, the full voltage span is twice the magnitude. For example, a unipolar range with a full-scale voltage of 5V has a range of 0V to 5V, for a total span of 5V. However, a bipolar range with a full-scale voltage of 5V has a range of $\pm 5\text{V}$, for a total span of 10V. Here is a brief overview of the relationship between output code and output voltage:

<u>Output Code</u>	<u>Explanation</u>	<u>Output Voltage for $\pm 5\text{V}$ Range</u>
0	Negative full scale	-5V
1	Negative full scale + 1 LSB	-4.9976V
2047	-1 LSB	-.0024V (-2.44mV)
2048	0V	0V
2049	+1 LSB	+.0024V (+2.44mV)
4095	Positive full scale - 1 LSB	+4.9976V

⇒ **Note:** Again, an output code of 4096 would be required to generate the positive-full-scale output voltage, but since that is impossible, the maximum output voltage is 1 LSB less than positive full scale.

11. HOW TO GENERATE AN ANALOG OUTPUT

This chapter describes how to generate an analog output directly (without the use of the driver software). Ruby-MM-1612 has 12-bit resolution analog outputs. However, data is written to the board in 8-bit bytes. Therefore two bytes must be written to the board to generate a single analog output. In addition, many applications require several channels to be updated simultaneously. In order to provide this ability, the update operation is separate from the data write operation.

Thus there are three steps required to generate an analog output. Each step is described in detail. The steps must be completed in the sequence shown below.

To generate an analog output on one or more channels:

1. Write the LSB (least significant byte) to the board at register Base + 0.
2. Write the channel number to the board at register Base + 2..
3. Write the MSB (most significant byte) to the board.
4. Repeat steps 1-3 for each channel to be changed
5. Update all changed channels by reading Base + 0 or Base + 1.

Hardware Update Command

A hardware update command can occur with a falling edge on the external trigger, pin 48 of J3.

To use hardware updating, or triggering, you must program the TRIGEN bit at Base + 3. See Chapter 3 for details.

⇒ **Note:** When a channel is updated, its output will change only if new data has been written to it since the last update. For example, if you do a simultaneous update on all channels but you only wrote data to channel 0, then only channel 0 will change, and channels 1 - 15 will stay the same.

⇒ **Note:** If hardware updating is enabled, software updating will still work.

Examples

Single channel output

Assume channels 0 - 7 are configured for 0-5V. To set channel 0 to 3V, do the following:

D/A code is $3V / 5V \times 4096 = 2458$ (value is rounded to nearest integer)

LSB = $2458 \text{ AND } 255 = 154$

MSB = $(2458 \text{ AND } 3840) / 256 = 9$

Step 1. Write **154** to base + 0 (LSB register).

Step 2. Write 0 to base + 2 (Channel register).

Step 3. Write **9** to base + 1 (MSB register). The value 2458 is written to DAC 0.

Step 4. Read from base + 0. DAC 0 now outputs 3.000V.

Two channel output

Assume channels 0 - 7 are configured for 0-5V. To set channel 0 to 3.8V and channel 3 to 1.5V, do the following:

D/A code for channel 0 = $3.8 / 5 \times 4096 = 3113$

LSB = $3113 \text{ AND } 255 = 41$

MSB = $(3113 \text{ AND } 3840) / 256 = 12$

D/A code for channel 1 = $1.5 / 5 \times 4096 = 1229$

LSB = $1229 \text{ AND } 255 = 205$

MSB = $(1229 \text{ AND } 3840) / 256 = 4$

Step 1. Write **41** to base + 0 (LSB register).

Step 2. Write 0 to base + 2 (Channel register).

Step 3. Write **12** to base + 1 (MSB register). The value 3113 is written to DAC 0.

Step 4. Write **205** to base + 0 (LSB register).

Step 5. Write 0 to base + 2 (Channel register).

Step 6. Write **4** to base + 1 (MSB register). The value 1229 is written to DAC 1.

Step 7. Read from base + 0. DAC 0 and DAC3 are both updated to their new output voltages. All other channels remain at their existing output voltages.

12. CALIBRATION PROCEDURE

Calibration requires a voltmeter (at least 5 digits of precision is preferred) and a miniature screwdriver to turn the potentiometer screws. The common lead of the voltmeter must be connected to analog ground (not digital ground). The best source for this connection is any of the analog ground pins on the user I/O header J3.

⇒ **Note:** All steps should be completed in the sequence shown, since each step affects the following steps. (Steps 4 and 5 may be interchanged since they do not depend on each other.)

+5.000V Reference Voltage Adjust

Install a jumper in position “5” on J4. Connect the high side lead of the voltmeter to the upper pin of J4 under either location marked “F”. Adjust **R1** so that the voltmeter reads +5.000V.

+10.00V Reference Voltage Adjust

Keep the voltmeter connected to as described above. Remove the jumper in position “5” on J4 and adjust **R2** so that the voltmeter reads +10.000V.

Adjustable Reference Adjust

This step can be skipped if you are not using the adjustable reference.

Connect the voltmeter to the upper pin of J4 below either location marked “A” on J4. Adjust **R3** so that the voltmeter reads the desired full-scale voltage range. This voltage is factory-preset to 2.500V. Any adjustment from about 1V to slightly over 2.5V is achievable.

Negative Full-Scale Reference Adjust, Channels 0 - 7

Install jumpers in positions “5” and the *leftmost* “F” on J4. Connect the voltmeter to the upper pin on J4 under the *leftmost* “B”. Adjust **R4** so that the voltmeter reads -4.999V . With this setting, the D/A will actually output closer to -5.000V when it is loaded with all zeros. This value can be adjusted later if desired by measuring the actual D/A output.

Negative Full-Scale Reference Adjust, Channels 8-15

Install jumpers in positions “5” and the *rightmost* “F” on J4. Connect the voltmeter to the upper pin on J4 under the *rightmost* “B”. Adjust **R5** so that the voltmeter reads -4.999V .

13. SPECIFICATIONS

Analog Outputs

No. of outputs	16 voltage outputs
Resolution	12 bits (1 part in 4096)
Fixed output ranges	0 - 5V, 0 - 10V unipolar, $\pm 5V$, $\pm 10V$ bipolar
Adjustable output range	Preset to 2.5V for 0 - 2.5V, $\pm 2.5V$ output ranges Can be adjusted anywhere between approx. 1V and 2.5V
External reference	0V min, 10V max
Settling time	6 μ s max to $\pm 0.01\%$
Accuracy	± 1 LSB
Integral nonlinearity	± 1 LSB max
Differential nonlinearity	-1LSB max, guaranteed monotonic
Output current	± 5 mA max per channel
Minimum output load	2K Ω
Update method	Simultaneous, software command or external trigger
Reset	All DACs reset to mid-scale (0V for bipolar ranges, 1/2 full-scale for unipolar ranges)

Digital I/O

No. of lines	24
Compatibility	CMOS / TTL
Input voltage	Logic 0: -0.5V min, 0.8V max Logic 1: 2.0V min, 5.5V max
Output voltage	Logic 0: 0.0V min, 0.4V max Logic 1: 3.0V min, $V_{cc} - 0.4V$ max
Output current	± 2.5 mA max per line
Pull-up resistor	10K Ω resistor on each I/O line
External trigger	TTL / CMOS compatible, 10K Ω pull-up resistor, active low edge
Reset	All digital output lines are set to 0

Miscellaneous

Power supply (V_{cc})	+5VDC $\pm 10\%$
Current requirement	430mA, all outputs unloaded
Operating temperature	-40 to +85 $^{\circ}$ C
Operating humidity	5 to 95% non-condensing
Size	3.55" x 3.775"
Data bus	8 bits (16-bit header can be installed for pass-through function but is not used on board)

CMOS Programmable Peripheral Interface

June 1998

Features

- Pin Compatible with NMOS 8255A
- 24 Programmable I/O Pins
- Fully TTL Compatible
- High Speed, No "Wait State" Operation with 5MHz and 8MHz 80C86 and 80C88
- Direct Bit Set/Reset Capability
- Enhanced Control Word Read Capability
- L7 Process
- 2.5mA Drive Capability on All I/O Ports
- Low Standby Power (ICCSB)10 μ A

Description

The Intersil 82C55A is a high performance CMOS version of the industry standard 8255A and is manufactured using a self-aligned silicon gate CMOS process (Scaled SAJI IV). It is a general purpose programmable I/O device which may be used with many different microprocessors. There are 24 I/O pins which may be individually programmed in 2 groups of 12 and used in 3 major modes of operation. The high performance and industry standard configuration of the 82C55A make it compatible with the 80C86, 80C88 and other microprocessors.

Static CMOS circuit design insures low operating power. TTL compatibility over the full military temperature range and bus hold circuitry eliminate the need for pull-up resistors. The Intersil advanced SAJI process results in performance equal to or greater than existing functionally equivalent products at a fraction of the power.

Ordering Information

PART NUMBERS		PACKAGE	TEMPERATURE RANGE	PKG. NO.
5MHz	8MHz			
CP82C55A-5	CP82C55A	40 Ld PDIP	0°C to 70°C	E40.6
IP82C55A-5	IP82C55A		-40°C to 85°C	E40.6
CS82C55A-5	CS82C55A	44 Ld PLCC	0°C to 70°C	N44.65
IS82C55A-5	IS82C55A		-40°C to 85°C	N44.65
CD82C55A-5	CD82C55A	40 Ld CERDIP	0°C to 70°C	F40.6
ID82C55A-5	ID82C55A		-40°C to 85°C	F40.6
MD82C55A-5/B	MD82C55A/B		-55°C to 125°C	F40.6
8406601QA	8406602QA		SMD#	F40.6
MR82C55A-5/B	MR82C55A/B	44 Pad CLCC	-55°C to 125°C	J44.A
8406601XA	8406602XA		SMD#	J44.A

Pinouts

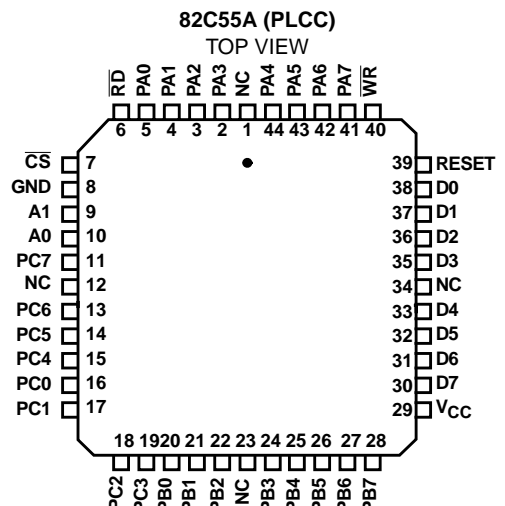
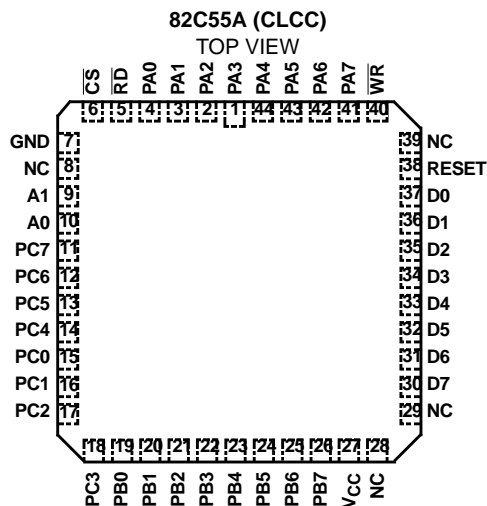
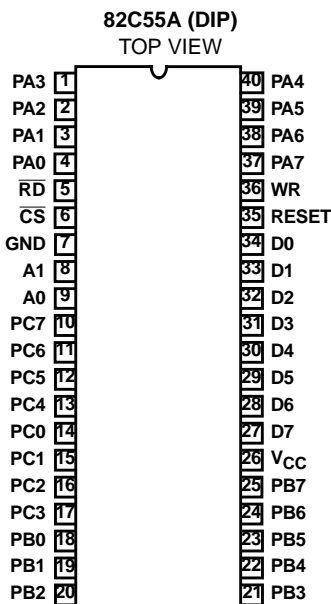

82C55A

Pin Description

SYMBOL	PIN NUMBER	TYPE	DESCRIPTION
V _{CC}	26		V _{CC} : The +5V power supply pin. A 0.1μF capacitor between pins 26 and 7 is recommended for decoupling.
GND	7		GROUND
D0-D7	27-34	I/O	DATA BUS: The Data Bus lines are bidirectional three-state pins connected to the system data bus.
RESET	35	I	RESET: A high on this input clears the control register and all ports (A, B, C) are set to the input mode with the "Bus Hold" circuitry turned on.
\overline{CS}	6	I	CHIP SELECT: Chip select is an active low input used to enable the 82C55A onto the Data Bus for CPU communications.
\overline{RD}	5	I	READ: Read is an active low input control signal used by the CPU to read status information or data via the data bus.
\overline{WR}	36	I	WRITE: Write is an active low input control signal used by the CPU to load control words and data into the 82C55A.
A0-A1	8, 9	I	ADDRESS: These input signals, in conjunction with the \overline{RD} and \overline{WR} inputs, control the selection of one of the three ports or the control word register. A0 and A1 are normally connected to the least significant bits of the Address Bus A0, A1.
PA0-PA7	1-4, 37-40	I/O	PORT A: 8-bit input and output port. Both bus hold high and bus hold low circuitry are present on this port.
PB0-PB7	18-25	I/O	PORT B: 8-bit input and output port. Bus hold high circuitry is present on this port.
PC0-PC7	10-17	I/O	PORT C: 8-bit input and output port. Bus hold circuitry is present on this port.

Functional Diagram

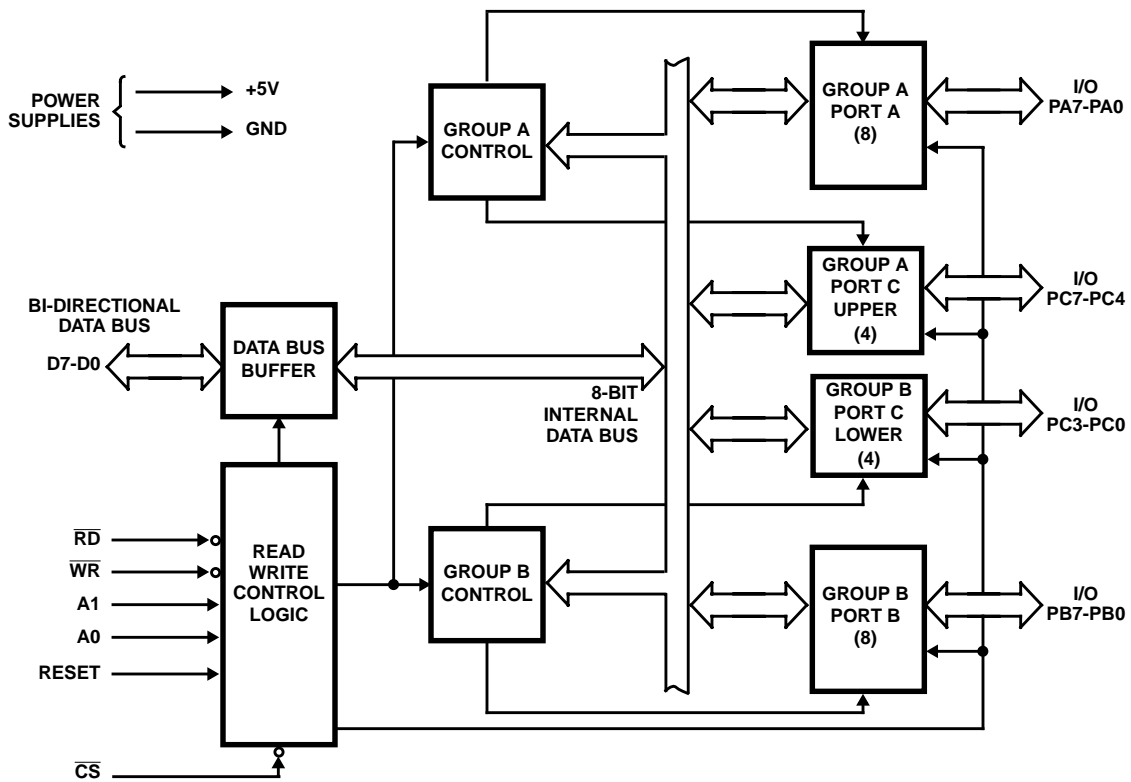

Functional Description

Data Bus Buffer

This three-state bi-directional 8-bit buffer is used to interface the 82C55A to the system data bus. Data is transmitted or received by the buffer upon execution of input or output instructions by the CPU. Control words and status information are also transferred through the data bus buffer.

Read/Write and Control Logic

The function of this block is to manage all of the internal and external transfers of both Data and Control or Status words. It accepts inputs from the CPU Address and Control busses and in turn, issues commands to both of the Control Groups.

(CS) Chip Select. A “low” on this input pin enables the communication between the 82C55A and the CPU.

(RD) Read. A “low” on this input pin enables 82C55A to send the data or status information to the CPU on the data bus. In essence, it allows the CPU to “read from” the 82C55A.

(WR) Write. A “low” on this input pin enables the CPU to write data or control words into the 82C55A.

(A0 and A1) Port Select 0 and Port Select 1. These input signals, in conjunction with the RD and WR inputs, control the selection of one of the three ports or the control word register. They are normally connected to the least significant bits of the address bus (A0 and A1).

82C55A BASIC OPERATION

A1	A0	RD	WR	CS	INPUT OPERATION (READ)
0	0	0	1	0	Port A → Data Bus
0	1	0	1	0	Port B → Data Bus
1	0	0	1	0	Port C → Data Bus
1	1	0	1	0	Control Word → Data Bus
OUTPUT OPERATION (WRITE)					
0	0	1	0	0	Data Bus → Port A
0	1	1	0	0	Data Bus → Port B
1	0	1	0	0	Data Bus → Port C
1	1	1	0	0	Data Bus → Control
DISABLE FUNCTION					
X	X	X	X	1	Data Bus → Three-State
X	X	1	1	0	Data Bus → Three-State

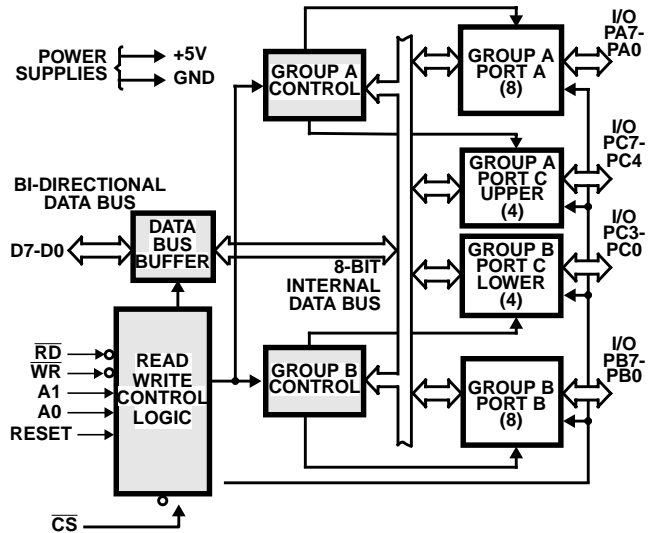

FIGURE 1. 82C55A BLOCK DIAGRAM. DATA BUS BUFFER, READ/WRITE, GROUP A & B CONTROL LOGIC FUNCTIONS

(RESET) Reset. A “high” on this input initializes the control register to 9Bh and all ports (A, B, C) are set to the input mode. “Bus hold” devices internal to the 82C55A will hold the I/O port inputs to a logic “1” state with a maximum hold current of 400µA.

Group A and Group B Controls

The functional configuration of each port is programmed by the systems software. In essence, the CPU “outputs” a control word to the 82C55A. The control word contains information such as “mode”, “bit set”, “bit reset”, etc., that initializes the functional configuration of the 82C55A.

Each of the Control blocks (Group A and Group B) accepts “commands” from the Read/Write Control logic, receives “control words” from the internal data bus and issues the proper commands to its associated ports.

Control Group A - Port A and Port C upper (C7 - C4)

Control Group B - Port B and Port C lower (C3 - C0)

The control word register can be both written and read as shown in the “Basic Operation” table. Figure 4 shows the control word format for both Read and Write operations. When the control word is read, bit D7 will always be a logic “1”, as this implies control word mode information.

Ports A, B, and C

The 82C55A contains three 8-bit ports (A, B, and C). All can be configured to a wide variety of functional characteristics by the system software but each has its own special features or "personality" to further enhance the power and flexibility of the 82C55A.

Port A One 8-bit data output latch/buffer and one 8-bit data input latch. Both "pull-up" and "pull-down" bus-hold devices are present on Port A. See Figure 2A.

Port B One 8-bit data input/output latch/buffer and one 8-bit data input buffer. See Figure 2B.

Port C One 8-bit data output latch/buffer and one 8-bit data input buffer (no latch for input). This port can be divided into two 4-bit ports under the mode control. Each 4-bit port contains a 4-bit latch and it can be used for the control signal output and status signal inputs in conjunction with ports A and B. See Figure 2B.

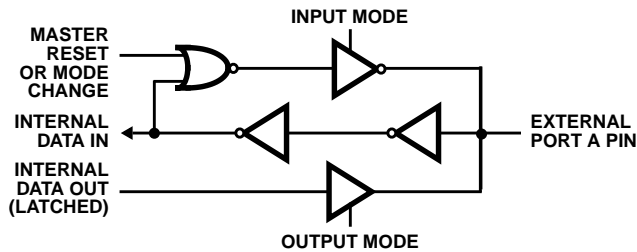

FIGURE 2A. PORT A BUS-HOLD CONFIGURATION

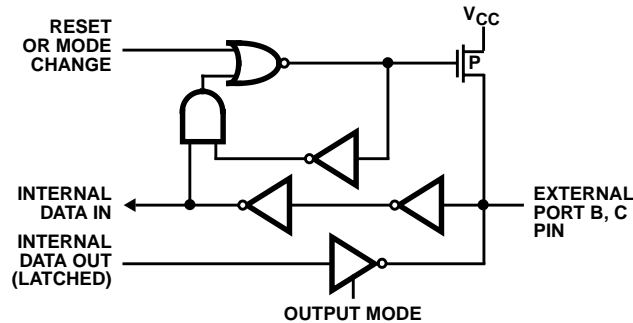

FIGURE 2B. PORT B AND C BUS-HOLD CONFIGURATION

FIGURE 2. BUS-HOLD CONFIGURATION

Operational Description

Mode Selection

There are three basic modes of operation that can be selected by the system software:

- Mode 0 - Basic Input/Output
- Mode 1 - Strobed Input/Output
- Mode 2 - Bi-directional Bus

When the reset input goes "high", all ports will be set to the input mode with all 24 port lines held at a logic "one" level by internal bus hold devices. After the reset is removed, the 82C55A can remain in the input mode with no additional initialization required. This eliminates the need to pullup or pull-down resistors in all-CMOS designs. The control word

register will contain 9Bh. During the execution of the system program, any of the other modes may be selected using a single output instruction. This allows a single 82C55A to service a variety of peripheral devices with a simple software maintenance routine. Any port programmed as an output port is initialized to all zeros when the control word is written.

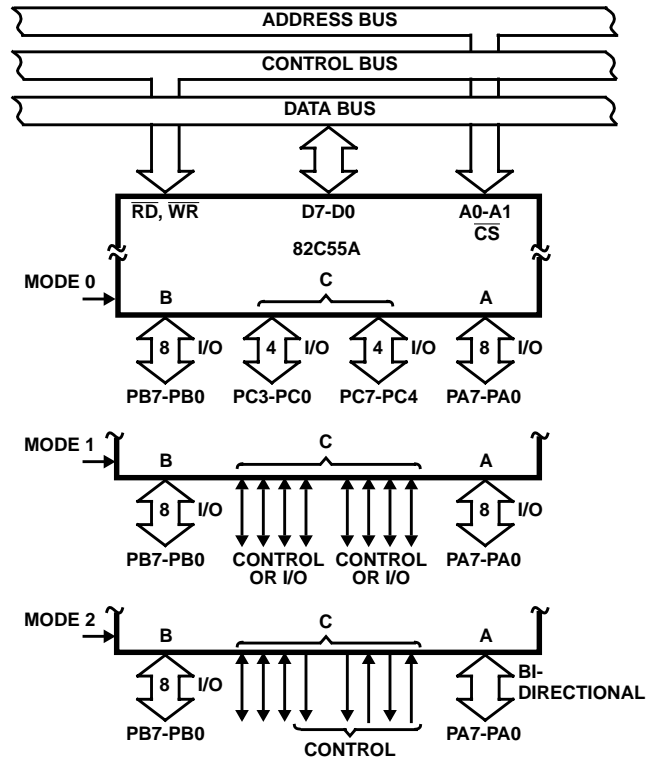

FIGURE 3. BASIC MODE DEFINITIONS AND BUS INTERFACE

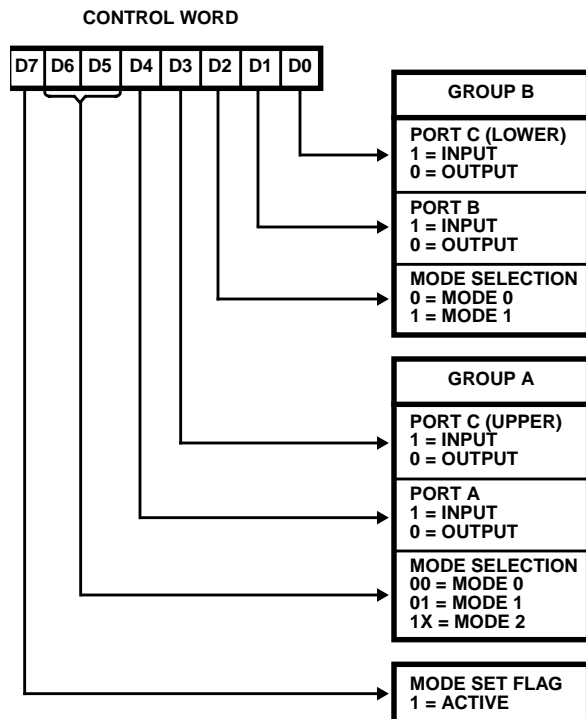

FIGURE 4. MODE DEFINITION FORMAT

The modes for Port A and Port B can be separately defined, while Port C is divided into two portions as required by the Port A and Port B definitions. All of the output registers, including the status flip-flops, will be reset whenever the mode is changed. Modes may be combined so that their functional definition can be "tailored" to almost any I/O structure. For instance: Group B can be programmed in Mode 0 to monitor simple switch closings or display computational results, Group A could be programmed in Mode 1 to monitor a keyboard or tape reader on an interrupt-driven basis.

The mode definitions and possible mode combinations may seem confusing at first, but after a cursory review of the complete device operation a simple, logical I/O approach will surface. The design of the 82C55A has taken into account things such as efficient PC board layout, control signal definition vs. PC layout and complete functional flexibility to support almost any peripheral device with no external logic. Such design represents the maximum use of the available pins.

Single Bit Set/Reset Feature (Figure 5)

Any of the eight bits of Port C can be Set or Reset using a single Output instruction. This feature reduces software requirements in control-based applications.

When Port C is being used as status/control for Port A or B, these bits can be set or reset by using the Bit Set/Reset operation just as if they were output ports.

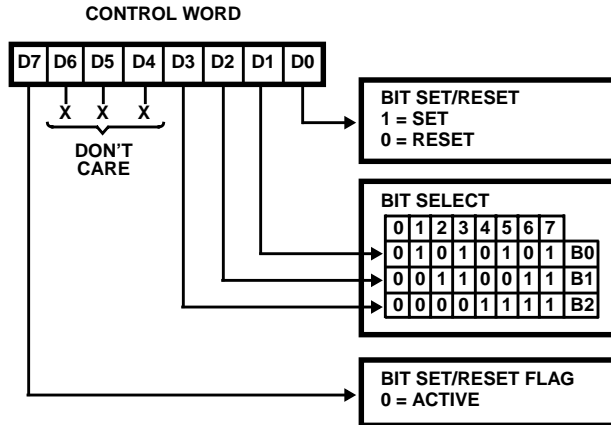

FIGURE 5. BIT SET/RESET FORMAT

Interrupt Control Functions

When the 82C55A is programmed to operate in mode 1 or mode 2, control signals are provided that can be used as interrupt request inputs to the CPU. The interrupt request signals, generated from port C, can be inhibited or enabled by setting or resetting the associated INTE flip-flop, using the bit set/reset function of port C.

This function allows the programmer to enable or disable a CPU interrupt by a specific I/O device without affecting any other device in the interrupt structure.

INTE Flip-Flop Definition

(BIT-SET)-INTE is SET - Interrupt Enable

(BIT-RESET)-INTE is Reset - Interrupt Disable

NOTE: All Mask flip-flops are automatically reset during mode selection and device Reset.

Operating Modes

Mode 0 (Basic Input/Output). This functional configuration provides simple input and output operations for each of the three ports. No handshaking is required, data is simply written to or read from a specific port.

Mode 0 Basic Functional Definitions:

- Two 8-bit ports and two 4-bit ports
- Any Port can be input or output
- Outputs are latched
- Input are not latched
- 16 different Input/Output configurations possible

MODE 0 PORT DEFINITION

A		B		GROUP A		#	GROUP B	
D4	D3	D1	D0	PORT A	PORTC (Upper)		PORT B	PORTC (Lower)
0	0	0	0	Output	Output	0	Output	Output
0	0	0	1	Output	Output	1	Output	Input
0	0	1	0	Output	Output	2	Input	Output
0	0	1	1	Output	Output	3	Input	Input
0	1	0	0	Output	Input	4	Output	Output
0	1	0	1	Output	Input	5	Output	Input
0	1	1	0	Output	Input	6	Input	Output
0	1	1	1	Output	Input	7	Input	Input
1	0	0	0	Input	Output	8	Output	Output
1	0	0	1	Input	Output	9	Output	Input
1	0	1	0	Input	Output	10	Input	Output
1	0	1	1	Input	Output	11	Input	Input
1	1	0	0	Input	Input	12	Output	Output
1	1	0	1	Input	Input	13	Output	Input
1	1	1	0	Input	Input	14	Input	Output
1	1	1	1	Input	Input	15	Input	Input

82C55A

Mode 0 (Basic Input)

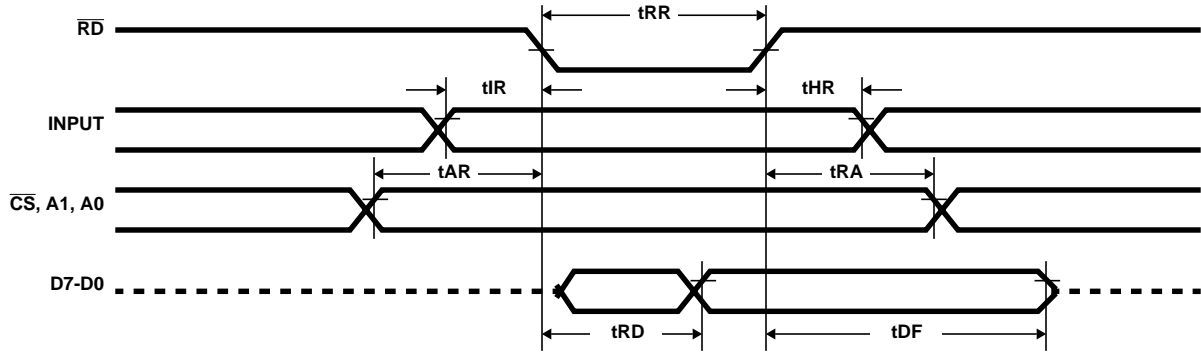

Mode 0 (Basic Output)

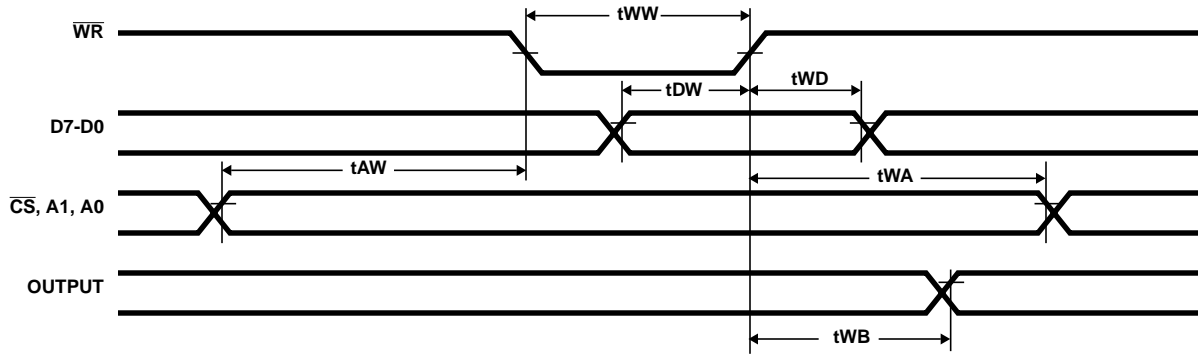

Mode 0 Configurations

CONTROL WORD #0

D7	D6	D5	D4	D3	D2	D1	D0
1	0	0	0	0	0	0	0

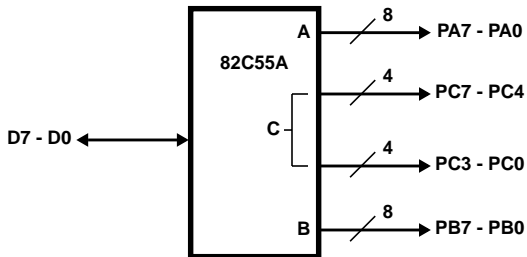

CONTROL WORD #2

D7	D6	D5	D4	D3	D2	D1	D0
1	0	0	0	0	0	1	0

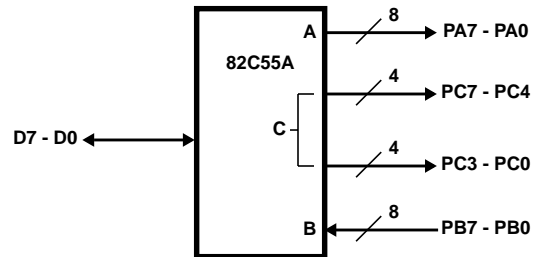

CONTROL WORD #1

D7	D6	D5	D4	D3	D2	D1	D0
1	0	0	0	0	0	0	1

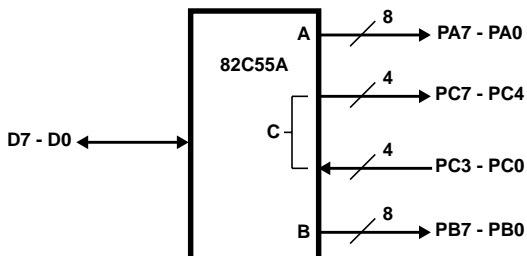

CONTROL WORD #3

D7	D6	D5	D4	D3	D2	D1	D0
1	0	0	0	0	0	1	1

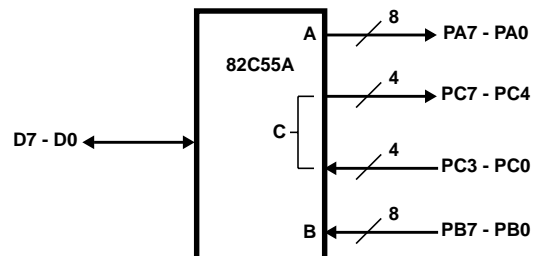

82C55A

Mode 0 Configurations (Continued)

CONTROL WORD #4

D7	D6	D5	D4	D3	D2	D1	D0
1	0	0	0	1	0	0	0

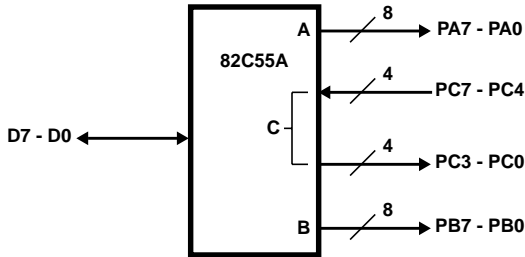

CONTROL WORD #8

D7	D6	D5	D4	D3	D2	D1	D0
1	0	0	1	0	0	0	0

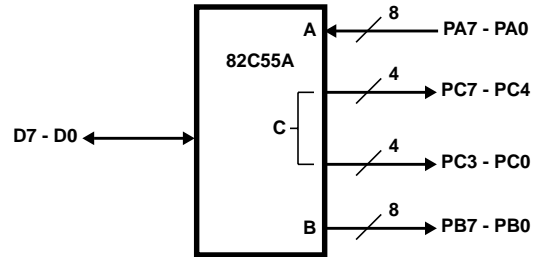

CONTROL WORD #5

D7	D6	D5	D4	D3	D2	D1	D0
1	0	0	0	1	0	0	1

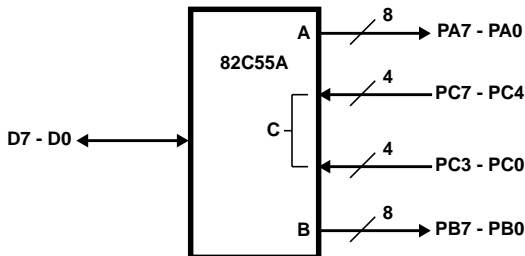

CONTROL WORD #9

D7	D6	D5	D4	D3	D2	D1	D0
1	0	0	1	0	0	0	1

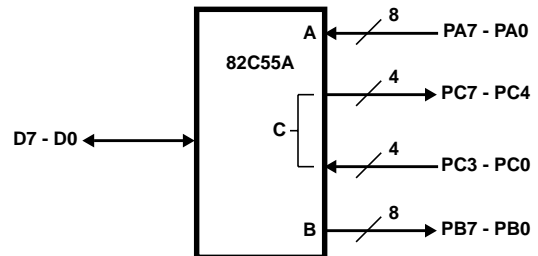

CONTROL WORD #6

D7	D6	D5	D4	D3	D2	D1	D0
1	0	0	0	1	0	1	0

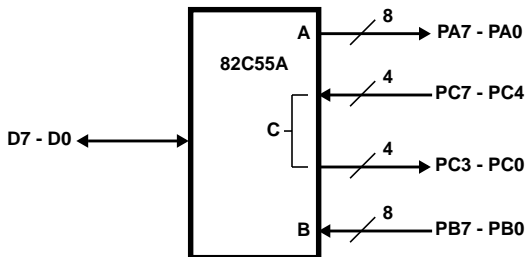

CONTROL WORD #10

D7	D6	D5	D4	D3	D2	D1	D0
1	0	0	1	0	0	1	0

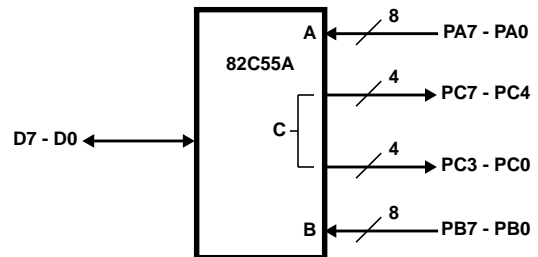

CONTROL WORD #7

D7	D6	D5	D4	D3	D2	D1	D0
1	0	0	0	1	0	1	1

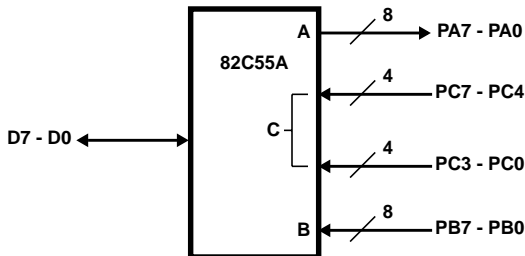

CONTROL WORD #11

D7	D6	D5	D4	D3	D2	D1	D0
1	0	0	1	0	0	1	1

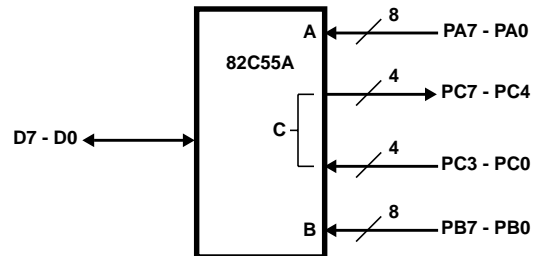

Mode 0 Configurations (Continued)

CONTROL WORD #12

D7	D6	D5	D4	D3	D2	D1	D0
1	0	0	1	1	0	0	0

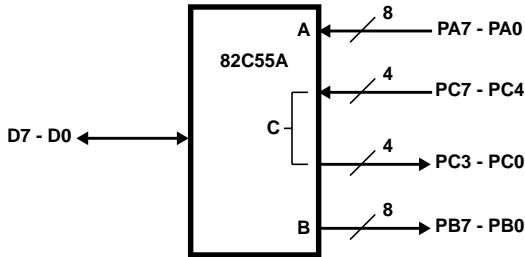

CONTROL WORD #14

D7	D6	D5	D4	D3	D2	D1	D0
1	0	0	1	1	0	1	0

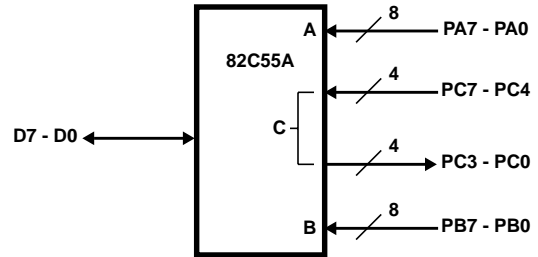

CONTROL WORD #13

D7	D6	D5	D4	D3	D2	D1	D0
1	0	0	1	1	0	0	1

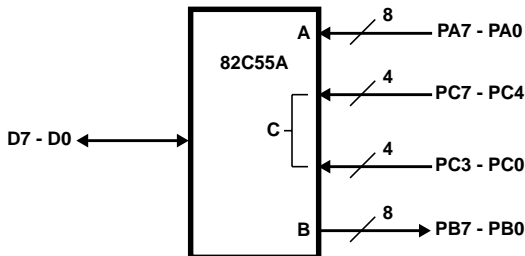

CONTROL WORD #15

D7	D6	D5	D4	D3	D2	D1	D0
1	0	0	1	1	0	1	1

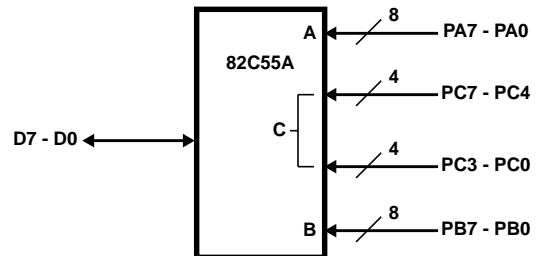

Operating Modes

Mode 1 - (Strobed Input/Output). This functional configuration provides a means for transferring I/O data to or from a specified port in conjunction with strobes or "hand shaking" signals. In mode 1, port A and port B use the lines on port C to generate or accept these "hand shaking" signals.

Mode 1 Basic Function Definitions:

- Two Groups (Group A and Group B)
- Each group contains one 8-bit port and one 4-bit control/data port
- The 8-bit data port can be either input or output. Both inputs and outputs are latched.
- The 4-bit port is used for control and status of the 8-bit port.

Input Control Signal Definition

(Figures 6 and 7)

STB (Strobe Input)

A "low" on this input loads data into the input latch.

IBF (Input Buffer Full F/F)

A "high" on this output indicates that the data has been loaded into the input latch: in essence, and acknowledgment. IBF is set by \overline{STB} input being low and is reset by the rising edge of the \overline{RD} input.

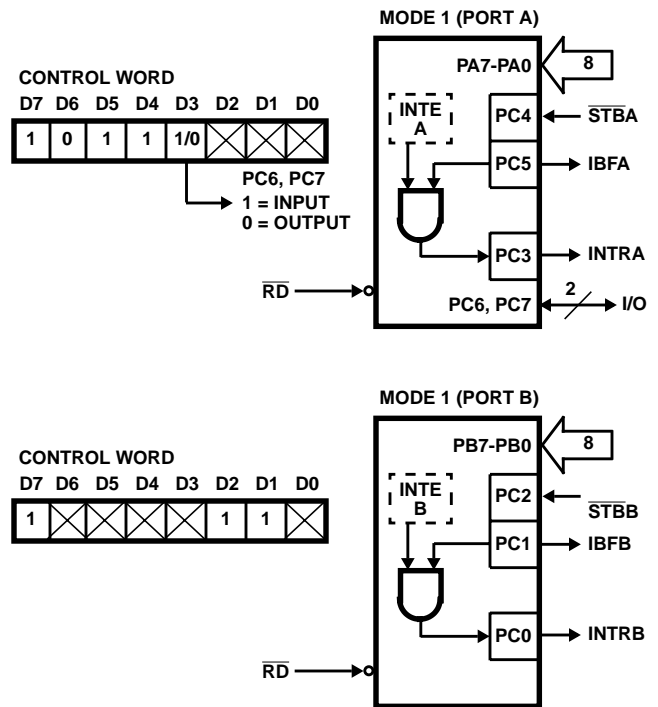

FIGURE 6. MODE 1 INPUT

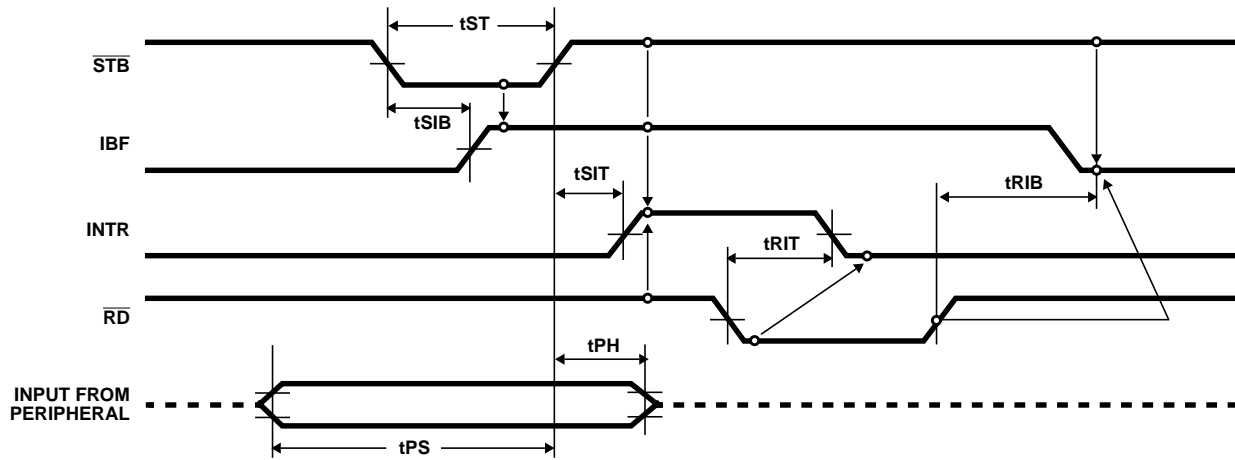

FIGURE 7. MODE 1 (STROBED INPUT)

INTR (Interrupt Request)

A "high" on this output can be used to interrupt the CPU when an input device is requesting service. \overline{INTR} is set by the condition: \overline{STB} is a "one", \overline{IBF} is a "one" and \overline{INTE} is a "one". It is reset by the falling edge of \overline{RD} . This procedure allows an input device to request service from the CPU by simply strobing its data into the port.

INTE A

Controlled by bit set/reset of PC4.

INTE B

Controlled by bit set/reset of PC2.

Output Control Signal Definition

(Figure 8 and 9)

\overline{OBF} - Output Buffer Full F/F. The \overline{OBF} output will go "low" to indicate that the CPU has written data out to be specified port. This does not mean valid data is sent out of the port at this time since \overline{OBF} can go true before data is available. Data is guaranteed valid at the rising edge of \overline{OBF} , (See Note 1). The \overline{OBF} F/F will be set by the rising edge of the \overline{WR} input and reset by \overline{ACK} input being low.

\overline{ACK} - Acknowledge Input. A "low" on this input informs the 82C55A that the data from Port A or Port B is ready to be accepted. In essence, a response from the peripheral device indicating that it is ready to accept data, (See Note 1).

\overline{INTR} - (Interrupt Request). A "high" on this output can be used to interrupt the CPU when an output device has accepted data transmitted by the CPU. \overline{INTR} is set when \overline{ACK} is a "one", \overline{OBF} is a "one" and \overline{INTE} is a "one". It is reset by the falling edge of \overline{WR} .

INTE A

Controlled by Bit Set/Reset of PC6.

INTE B

Controlled by Bit Set/Reset of PC2.

NOTE:

- To strobe data into the peripheral device, the user must operate the strobe line in a hand shaking mode. The user needs to send \overline{OBF} to the peripheral device, generates an \overline{ACK} from the peripheral device and then latch data into the peripheral device on the rising edge of \overline{OBF} .

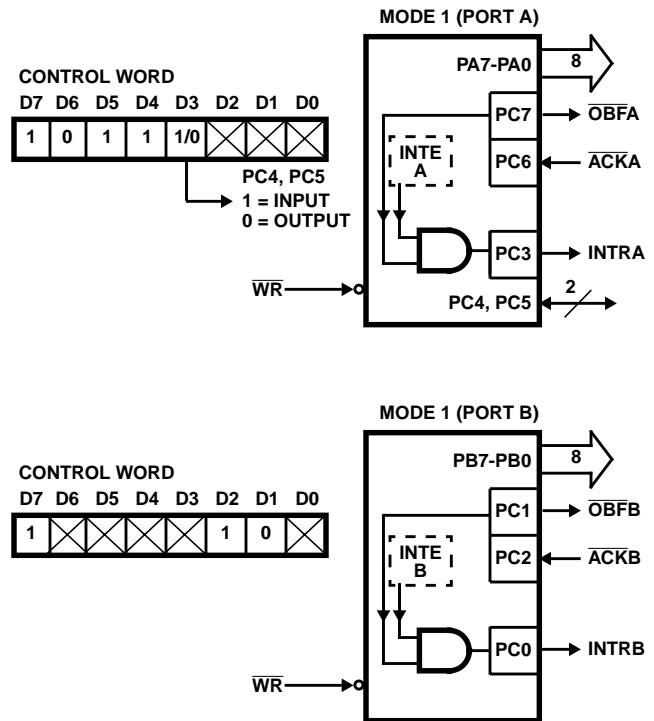

FIGURE 8. MODE 1 OUTPUT

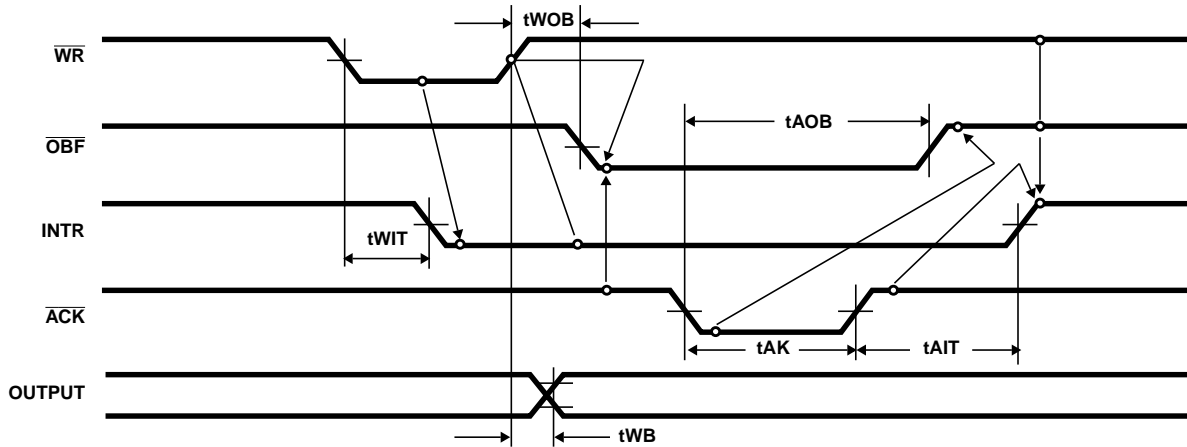

FIGURE 9. MODE 1 (STROBED OUTPUT)

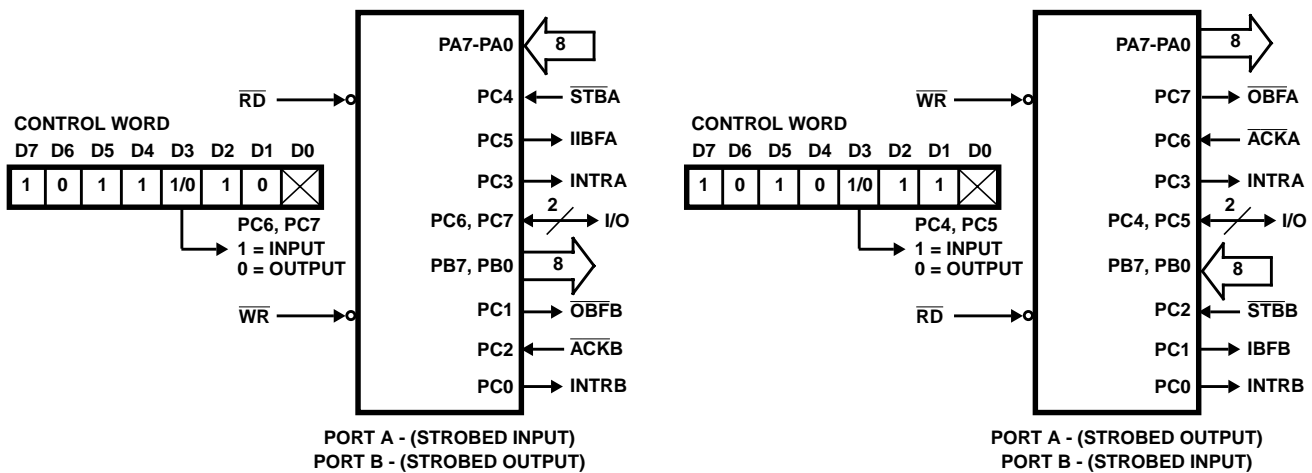

FIGURE 10. COMBINATIONS OF MODE 1

Combinations of Mode 1: Port A and Port B can be individually defined as input or output in Mode 1 to support a wide variety of strobed I/O applications.

Operating Modes

Mode 2 (Strobed Bi-Directional Bus I/O)

The functional configuration provides a means for communicating with a peripheral device or structure on a single 8-bit bus for both transmitting and receiving data (bi-directional bus I/O). "Hand shaking" signals are provided to maintain proper bus flow discipline similar to Mode 1. Interrupt generation and enable/disable functions are also available.

Mode 2 Basic Functional Definitions:

- Used in Group A only
- One 8-bit, bi-directional bus Port (Port A) and a 5-bit control Port (Port C)
- Both inputs and outputs are latched
- The 5-bit control port (Port C) is used for control and status for the 8-bit, bi-directional bus port (Port A)

Bi-Directional Bus I/O Control Signal Definition

(Figures 11, 12, 13, 14)

INTR - (Interrupt Request). A high on this output can be used to interrupt the CPU for both input or output operations.

Output Operations

OBF - (Output Buffer Full). The $\overline{\text{OBF}}$ output will go "low" to indicate that the CPU has written data out to port A.

ACK - (Acknowledge). A "low" on this input enables the three-state output buffer of port A to send out the data. Otherwise, the output buffer will be in the high impedance state.

INTE 1 - (The INTE flip-flop associated with $\overline{\text{OBF}}$). Controlled by bit set/reset of PC4.

Input Operations

STB - (Strobe Input). A "low" on this input loads data into the input latch.

IBF - (Input Buffer Full F/F). A "high" on this output indicates that data has been loaded into the input latch.

INTE 2 - (The INTE flip-flop associated with IBF). Controlled by bit set/reset of PC4.

82C55A

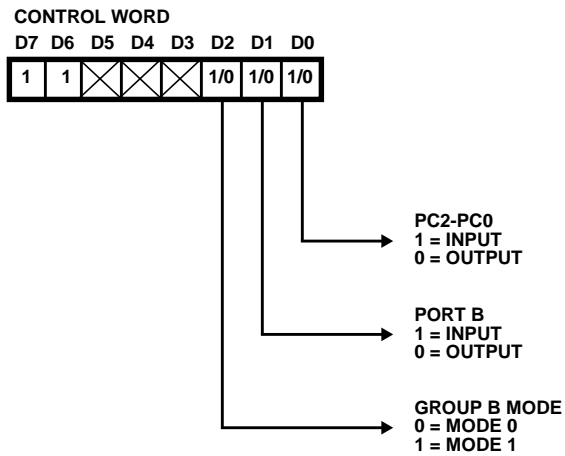

FIGURE 11. MODE CONTROL WORD

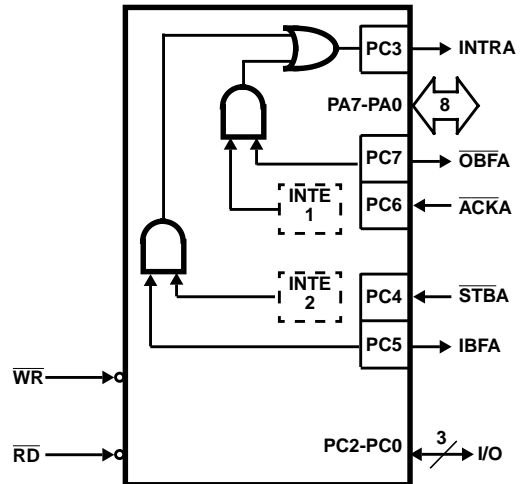
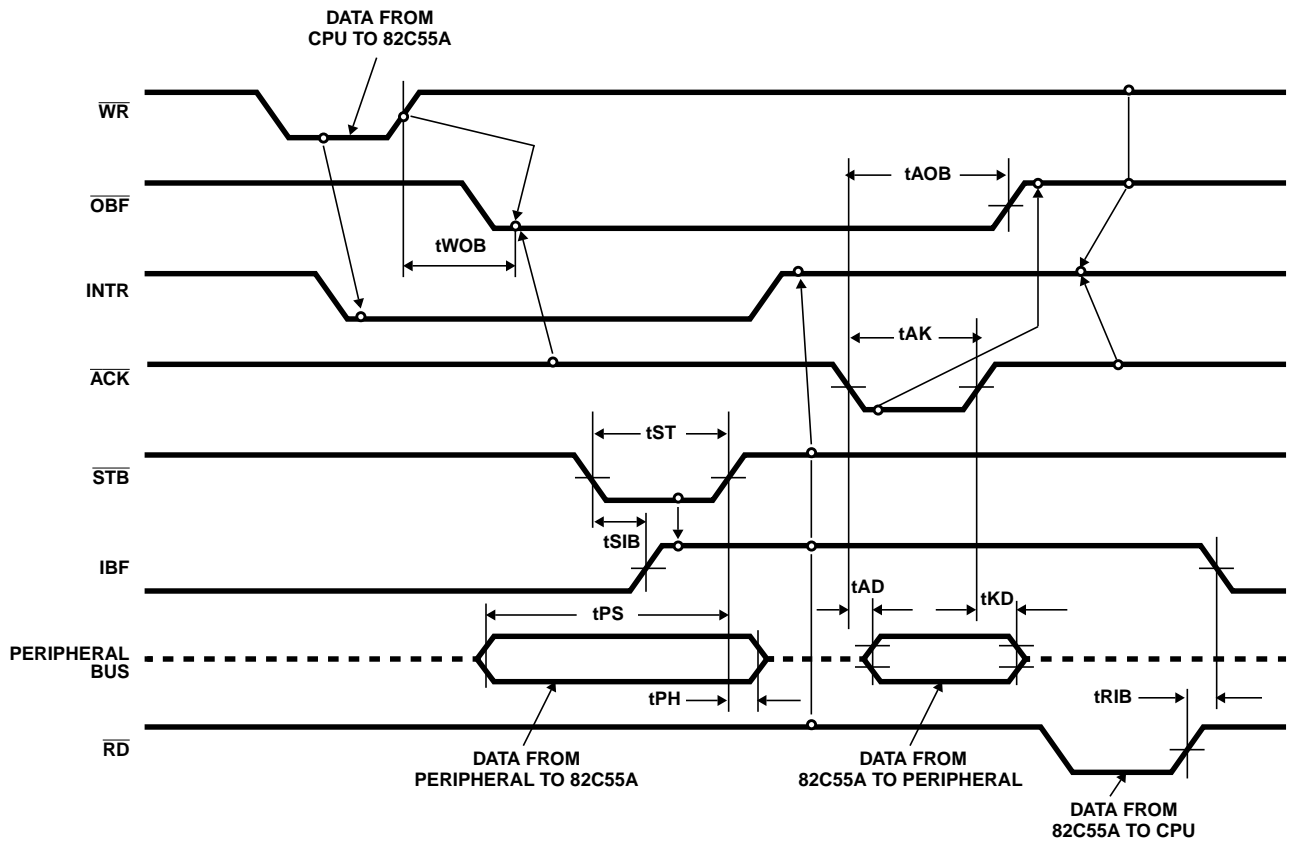

FIGURE 12. MODE 2



NOTE: Any sequence where \overline{WR} occurs before \overline{ACK} and \overline{STB} occurs before RD is permissible. ($INTR = IBF \cdot MASK \cdot \overline{STB} \cdot \overline{RD} \div \overline{OBF} \cdot MASK \cdot ACK \cdot WR$)

FIGURE 13. MODE 2 (BI-DIRECTIONAL)

82C55A

MODE 2 AND MODE 0 (INPUT)

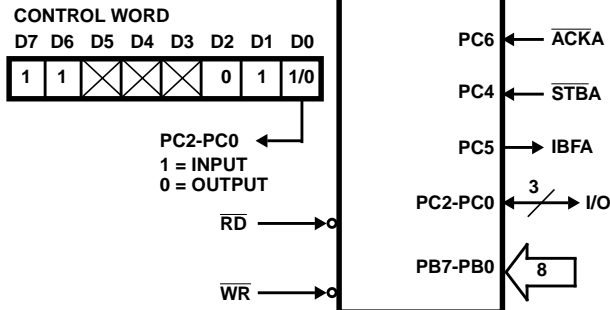

MODE 2 AND MODE 0 (OUTPUT)

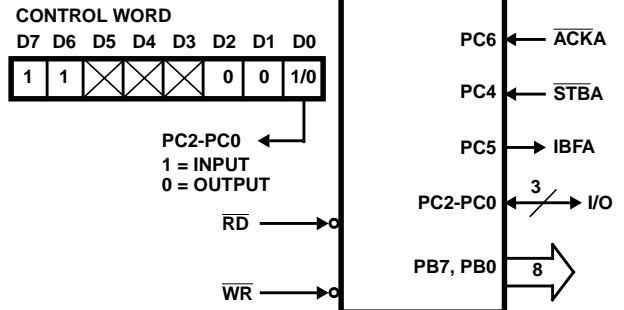

MODE 2 AND MODE 1 (OUTPUT)

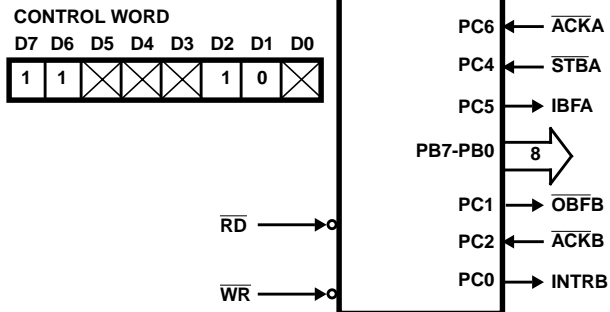

MODE 2 AND MODE 1 (INPUT)

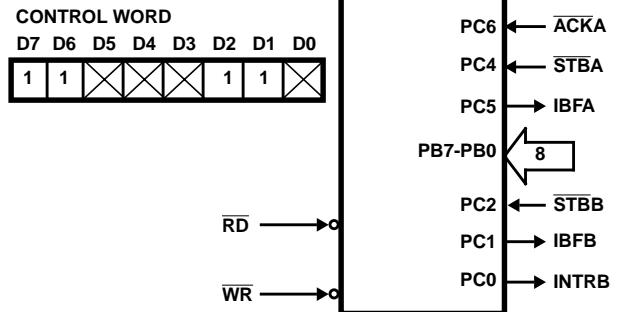

FIGURE 14. MODE 2 COMBINATIONS

MODE DEFINITION SUMMARY

	MODE 0		MODE 1		MODE 2
	IN	OUT	IN	OUT	GROUP A ONLY
PA0	In	Out	In	Out	↔
PA1	In	Out	In	Out	↔
PA2	In	Out	In	Out	↔
PA3	In	Out	In	Out	↔
PA4	In	Out	In	Out	↔
PA5	In	Out	In	Out	↔
PA6	In	Out	In	Out	↔
PA7	In	Out	In	Out	↔
PB0	In	Out	In	Out	} Mode 0 or Mode 1 Only
PB1	In	Out	In	Out	
PB2	In	Out	In	Out	
PB3	In	Out	In	Out	
PB4	In	Out	In	Out	
PB5	In	Out	In	Out	
PB6	In	Out	In	Out	
PB7	In	Out	In	Out	
PC0	In	Out	INTRB	INTRB	I/O
PC1	In	Out	IBFB	OBFB	I/O
PC2	In	Out	STBB	ACKB	I/O
PC3	In	Out	INTRA	INTRA	INTRA
PC4	In	Out	STBA	I/O	STBA
PC5	In	Out	IBFA	I/O	IBFA
PC6	In	Out	I/O	ACKA	ACKA
PC7	In	Out	I/O	OBFA	OBFA

Special Mode Combination Considerations

There are several combinations of modes possible. For any combination, some or all of Port C lines are used for control or status. The remaining bits are either inputs or outputs as defined by a "Set Mode" command.

During a read of Port C, the state of all the Port C lines, except the \overline{ACK} and \overline{STB} lines, will be placed on the data bus. In place of the \overline{ACK} and \overline{STB} line states, flag status will appear on the data bus in the PC2, PC4, and PC6 bit positions as illustrated by Figure 17.

Through a "Write Port C" command, only the Port C pins programmed as outputs in a Mode 0 group can be written. No other pins can be affected by a "Write Port C" command, nor can the interrupt enable flags be accessed. To write to any Port C output programmed as an output in Mode 1 group or to change an interrupt enable flag, the "Set/Reset Port C Bit" command must be used.

With a "Set/Reset Port Cea Bit" command, any Port C line programmed as an output (including IBF and \overline{OB}) can be written, or an interrupt enable flag can be either set or reset. Port C lines programmed as inputs, including \overline{ACK} and \overline{STB} lines, associated with Port C fare not affected by a "Set/Reset Port C Bit" command. Writing to the corresponding Port C bit positions of the \overline{ACK} and \overline{STB} lines with the "Set Reset Port C Bit" command will affect the Group A and Group B interrupt enable flags, as illustrated in Figure 17.

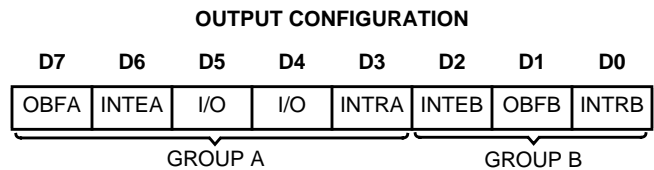
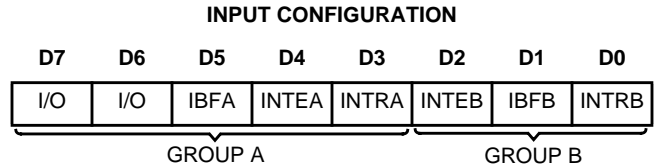

FIGURE 15. MODE 1 STATUS WORD FORMAT

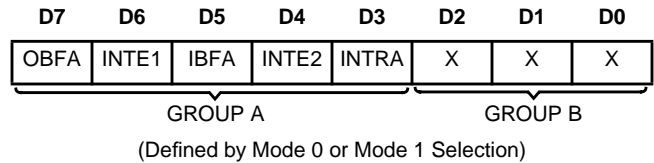

FIGURE 16. MODE 2 STATUS WORD FORMAT

Current Drive Capability

Any output on Port A, B or C can sink or source 2.5mA. This feature allows the 82C55A to directly drive Darlington type drivers and high-voltage displays that require such sink or source current.

Reading Port C Status (Figures 15 and 16)

In Mode 0, Port C transfers data to or from the peripheral device. When the 82C55A is programmed to function in Modes 1 or 2, Port C generates or accepts "hand shaking" signals with the peripheral device. Reading the contents of Port C allows the programmer to test or verify the "status" of each peripheral device and change the program flow accordingly.

There is not special instruction to read the status information from Port C. A normal read operation of Port C is executed to perform this function.

INTERRUPT ENABLE FLAG	POSITION	ALTERNATE PORT C PIN SIGNAL (MODE)
INTE B	PC2	\overline{ACKB} (Output Mode 1) or \overline{STBB} (Input Mode 1)
INTE A2	PC4	\overline{STBA} (Input Mode 1 or Mode 2)
INTE A1	PC6	\overline{ACKA} (Output Mode 1 or Mode 2)

FIGURE 17. INTERRUPT ENABLE FLAGS IN MODES 1 AND 2

Applications of the 82C55A

The 82C55A is a very powerful tool for interfacing peripheral equipment to the microcomputer system. It represents the optimum use of available pins and flexible enough to interface almost any I/O device without the need for additional external logic.

Each peripheral device in a microcomputer system usually has a "service routine" associated with it. The routine manages the software interface between the device and the CPU. The functional definition of the 82C55A is programmed by the I/O service routine and becomes an extension of the system software. By examining the I/O devices interface characteristics for both data transfer and timing, and matching this information to the examples and tables in the detailed operational description, a control word can easily be developed to initialize the 82C55A to exactly "fit" the application. Figures 18 through 24 present a few examples of typical applications of the 82C55A.

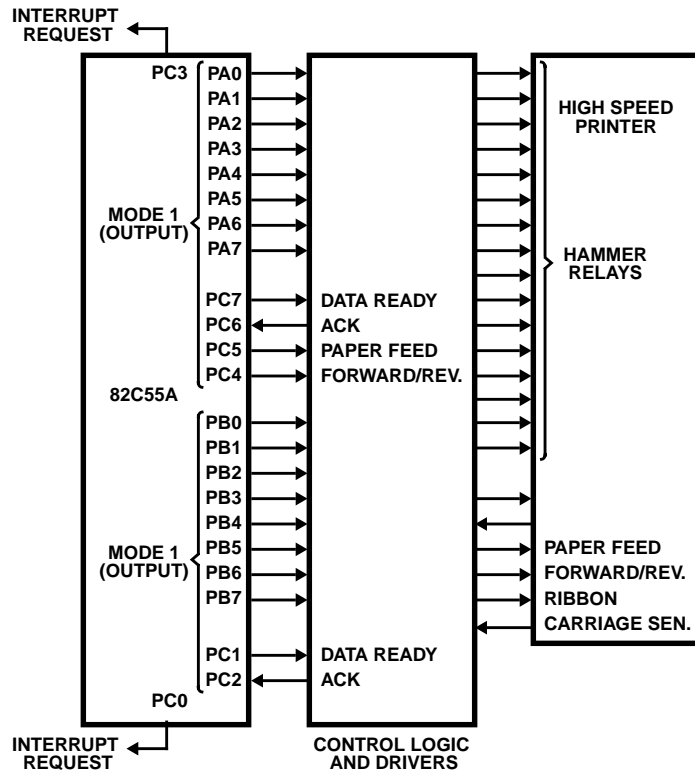

FIGURE 18. PRINTER INTERFACE